

Automatic passenger counting

IRMA – Infrared Motion Analyser 5th generation

IRMA MATRIX

**Start on the PC via Ethernet
Operating Instructions**

For the service software variants of

- IRMA-MATRIX-Configuration
- IRMA-MATRIX-Visualization
- IRMA-TestRide-IRMA MATRIX



iris INFRARED
INTELLIGENT
SENSORS

Document information

Title of document:	Starting IRMA MATRIX on the PC via Ethernet
Revision:	1.2
Edition (YYYY-MM):	2016-02
Type of document:	Customer documentation
Status:	released

Document history

Rev.	Date	Name	Comments/modifications
1.2	24.02.2016	VEGI	First edition
1.2	29.02.2016	VEGI	Page 6: changed "IP address" - >"IP address range"

Validity

Sensors and connectors covered by this document:

Product	Component	Product designation	Description
IRMA MATRIX	DIST500-A	DIST500.7-A07.OC	Sensor of the surface mount version
IRMA MATRIX	DIST500-F	DIST500.7-F07.OC	Sensor of the flush mount version
	sCON-S	sCON-S-CAN-ETH-23-Kq-x-y	Standard connector with interfaces CAN, Ethernet for MATRIX sensors
	sCON-S	sCON-S-ETH-22-Kq-x-y	Standard connector with interfaces CAN, Ethernet for MATRIX sensors

Table of contents

1	General.....	4
1.1	Symbols / abbreviations used	4
1.2	Brief description	4
2	Preparation	5
2.1	Equipment required	5
2.2	Overview of the necessary steps of work	6
3	Checking the settings in the network architecture	6
4	Making the IP settings (PC)	6
4.1	Changing (setting) the IP address of your PC network adapter	7
4.2	Setting as a second IP address	8
5	Switching off the WLAN	10
6	Connecting the sensor	11
6.1	PC connection with a standard connector of the type sCON-S-CAN-ETH-23-Kq-x-y	11
6.2	PC connection with a standard connector of the sCON-S-ETH-22-Kq-x-y type	12
7	Starting the service software	13
7.1	Before the first run of the service software program	13
7.2	Important at each start of the software.....	14
7.2.1	DIST500-Configuration_3.3.1.142 (or higher)	14
7.2.2	DIST500-Visualization_4.2.0.112 (or higher)	14
7.2.3	IRMA TestRide 2.8.1.37 (or higher).....	14
8	Restoring the initial state at the PC	15

Table of illustrations

Figure 1:	Select Internet protocol type 4(TCP/IPv4), right: Enter IP address	7
Figure 2:	How to enter the extended PCP/IP settings	8
Figure 3:	Entering the IP address for IRMA MATRIX as a second entry	9
Figure 4:	PC connection with sCON-S-CAN-ETH-23-Kq-x-y standard	11
Figure 5:	PC connection with sCON-S-ETH-22-Kq-x-y	12
Figure 7:	Entry in the "Properties" window of a service software tool	13

1 General

1.1 Symbols / abbreviations used



"Please note!"



"Information"



"Instructions"



"Download"



"See Annex"



"See document on our website"

M12CAN-CON-03 iris product designation / name of an IRMA MATRIX component

sCON Connector for IRMA MATRIX sensors

Connector (f) Female connector

Connector (m) Male connector

x, y Variable cable executions or variable cable lengths

XX or Kq Cable available in 2 different cable qualities

"Advanced" Name of a window or button

1.2 Brief description

These instructions describe the steps required for connecting an IRMA MATRIX sensor to any PC. Afterwards, a suitable software program enables for example the check of the condition on delivery, configuration of the sensor properties, updating of the firmware or viewing of the sensor graphic data. Communication between the sensor and the PC is effected via Ethernet.

2 Preparation

2.1 Equipment required

- PC with Windows XP operating system or higher
- IRMA-MATRIX sensor(s)
- Service software programs for IRMA MATRIX sensors



Can be downloaded from www.irisgmbh.de: in the following variants:

- **DIST500-Configuration** (for sensor configuration)
- **DIST500-Visualization** (visualizes the measuring characteristics of a sensor)
- **IRMA TestRide, IRMA MATRIX** (for signal recording on test rides)

What is required for connecting an IRMA MATRIX sensor to the PC:

1. **24 V power block M12** with M12 connecting cable: M12 connector (f, 5 poles, A coded). The power block is available as an accessory.
2. The following sensor-connector combinations can be used for servicing IRMA MATRIX sensors via Ethernet:

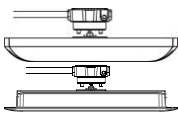

- Type **sCON-S-CAN-ETH-23-Kq-x-y** with interfaces CAN, Ethernet for MATRIX sensors (see also [Figure 4](#), page 11).
 - Type **sCON-S-ETH-22-Kq-x-y** with Ethernet interface for MATRIX sensors (see [Figure 5](#), p. 12)
3. Commercial Ethernet switch with several RJ45 or M12 slots.
 4. M12/RJ45 adapter cable **KQ-M12CAT5-RJ45-01-xm** (accessory)
M12 connector (male, 4 poles, D coded) to RJ45 connector (male) for PC connection
x = 2 m/10 m.



All cables and components used here are described in detail in the "M12 components for Ethernet installations" catalogue.

2.2 Overview of the necessary steps of work

1. Downloading the software to your PC
2. Checking the settings in the network architecture
3. Setting the IP address for your PC
4. Deactivating WLAN
5. Connecting the sensor(s)
6. Performing the servicing work on the sensor
7. Restoring the original settings of the PC network adapter

3 Checking the settings in the network architecture



The following UDP ports must be released for the network architecture:

34952

34953

34954

Otherwise, there will be no connection!

4 Making the IP settings (PC)

The sensor has its own IP address which can be configured. In condition as delivered it starts as follows: (10.x.x.x). However, it can deviate due to customer-specific configuration requests.



For the PC to recognize the sensor and communicate with it, the PC must use the same IP address range. Therefore the IP address of the PC network adapter must be changed or else an additional IP address range entered. For this purpose any address from the IP address range of (10.0.0.x) with x = 11 ... 249 can be used.

The system does not support DHCP.

4.1 Changing (setting) the IP address of your PC network adapter

Select or open the following windows one after the other:

For Windows XP:

- 1.a "Control Panel" \ "Network Settings" \ "Local Area Connection" \ "Properties" \ "Internet Protocol (TCP/IP)" \ "Properties"

For Windows 7/8:

- 1.b ► "Control Panel" ► "Network and Internet"¹ ► "Network and Sharing Center" \ "Local Area Connection" (for Windows 8: Ethernet connection)

In the "Local Area Connection Status" window click on the button "Properties". In the "Local Area Connection Status properties" window select the Internet Protocol Version 4 (TCP/IPv4) by clicking on it (see Figure 1 to the left) and click on the "Properties" button.

For Windows XP, 7, 8

2. If in the "Internet Protocol Version 4 (TCP/Pv4) Properties" window the setting "Obtain an IP address automatically" is activated, the setting must be changed to "Use the following IP Address" (see Figure 1 on the right).



If the setting "Use the following IP Address" has been activated, the IP address for the sensors can be set as a second IP setting (see section 4.2 on page 8).

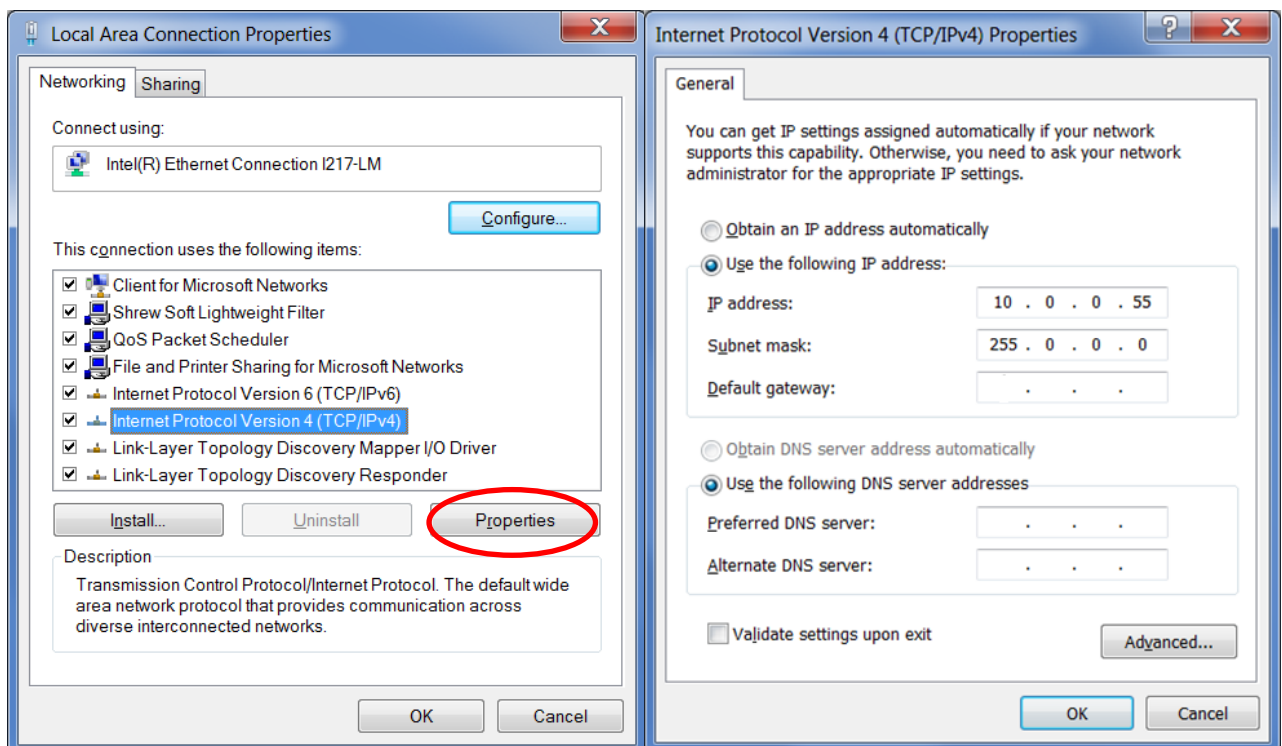

Figure 1: Select Internet protocol type 4(TCP/IPv4), right: Enter IP address

¹ For "Network and Internet", "All Control Panel Items" can also be the right choice.

3. Then the items of the IP address can be activated for entry by a mouse-click.



The following entries are possible:

IP address: **10.0.0.x** with x = **11 – 249**

The first **10** IP addresses are mostly reserved for other services. Please do not use them. We are using x = 55 for our example (see Figure 1 on the right).

4. **For our example please enter:**

"IP address:" | 10 | 0 | 0 | 55 |

"Subnetwork mask:" | 255 | 0 | 0 | 0 |



Please do not make any entries for the "Standard gateway" or DNS server.

4.2 Setting as a second IP address

If the setting "Obtain an IP address automatically" has been activated (see Figure 2 on the right), the IP address for the sensors can also be used as a second IP setting:

- For this purpose press the "Advanced..." button. (see Figure 2 on the left), the "Advanced TCP/IP Settings" button opens (see Figure 2 on the right).

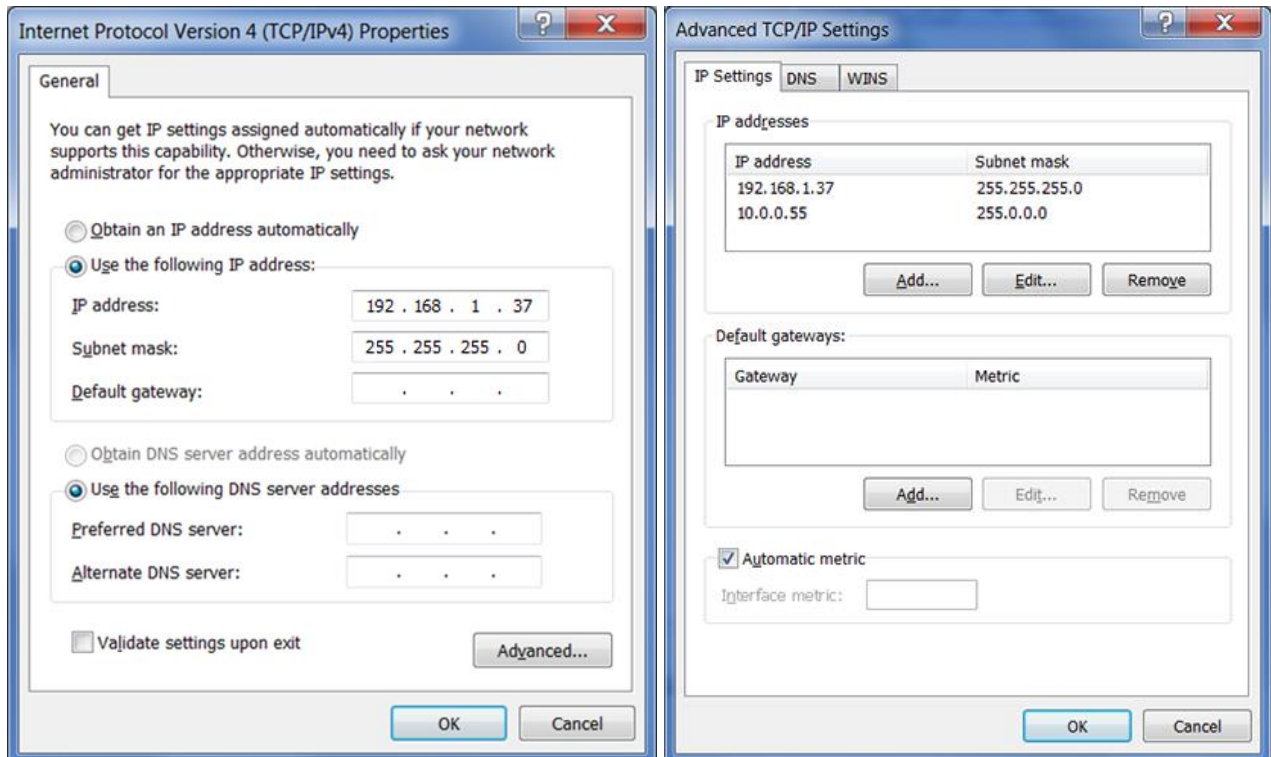

Figure 2: How to enter the extended TCP/IP settings

- On the "IP settings" tab in the "IP address" area click on the "Add..." button. The input mask "TCP/IP Address" opens, see Figure 3 on the left.
- **For our example please enter:**
"IP address:" | 10 | 0 | 0 | 55 |
"Subnet mask:" | 255 | 0 | 0 | 0 |
- Conclude the entry of the IP address by clicking "Add", it will appear as the second entry (see Figure 2 on the right).

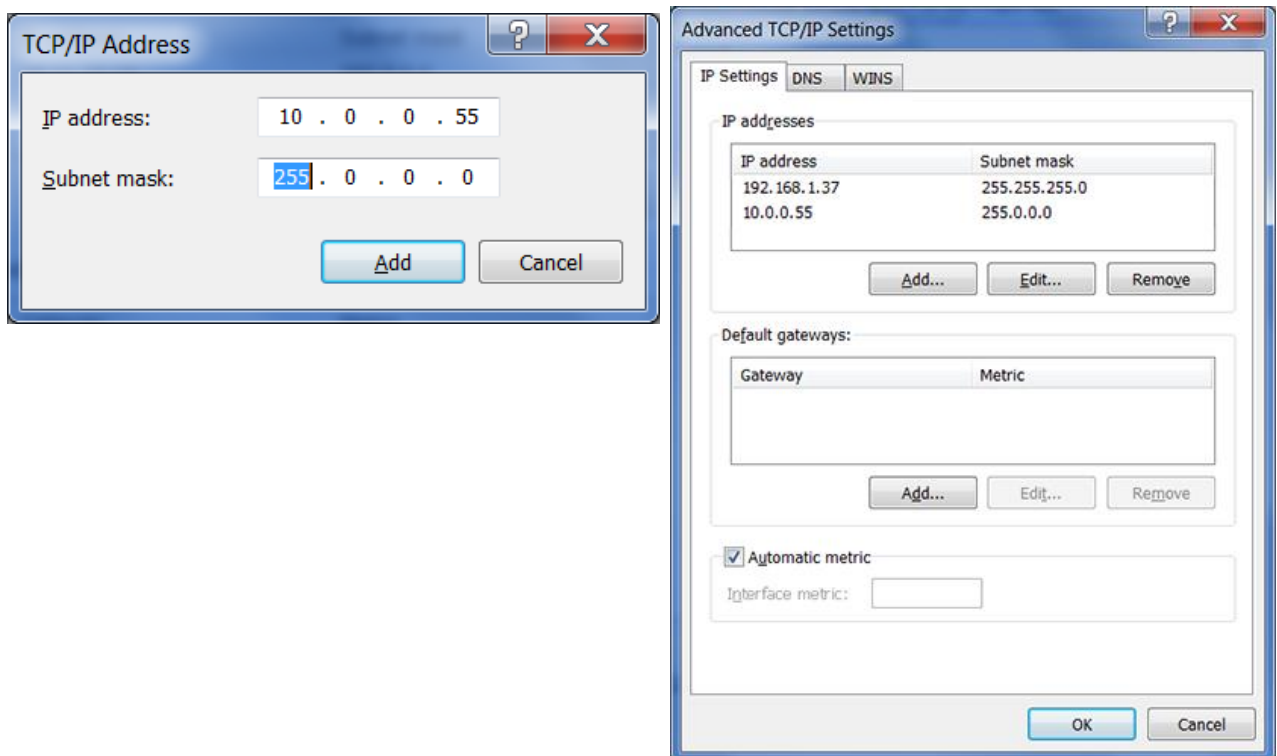

Figure 3: Entering the IP address for IRMA MATRIX as a second entry

5 Switching off the WLAN



In order to prevent communication problems, absolutely switch off the WLAN!

- If available, please switch off the WLAN hardware switch on the PC
or
- deactivate the WLAN symbol in the status bar or
- deactivate WLAN via the PC operating system via the path
▶ "Control Panel" ▶ "Network and Internet ²" ▶ "Manage Wireless Network"



On conclusion of the work with the sensor the original setting must be restored.

² For "Network and Internet", "All Control Panel Items" can also be the right choice.

6 Connecting the sensor

- ! The sensor and computer are connected via the Ethernet. The connection is made using an Ethernet switch.

6.1 PC connection with a standard connector of the type **sCON-S-CAN-ETH-23-Kq-x-y**

- 🔧 1. Connect the IRMA MATRIX sensor with the connector. See Figure 4.
- 2. Connect the Ethernet interface of the sensor (M12 female connector, 4 poles) to the M12 connector (male, 4 poles), using an adapter cable (see Figure 4 with item (4) or (5)).
- 3. Connect the adapter cable to the switch.
- 4. Connect the switch with the PC (see Figure 4 with item (4) or (6)).
- 5. Connect the CAN interface of the sensor (M12 male connector type CAN to the M12 female connector (type CAN) of the Power block (item 3).
- ! 6. The final step is to connect the power block to power supply!

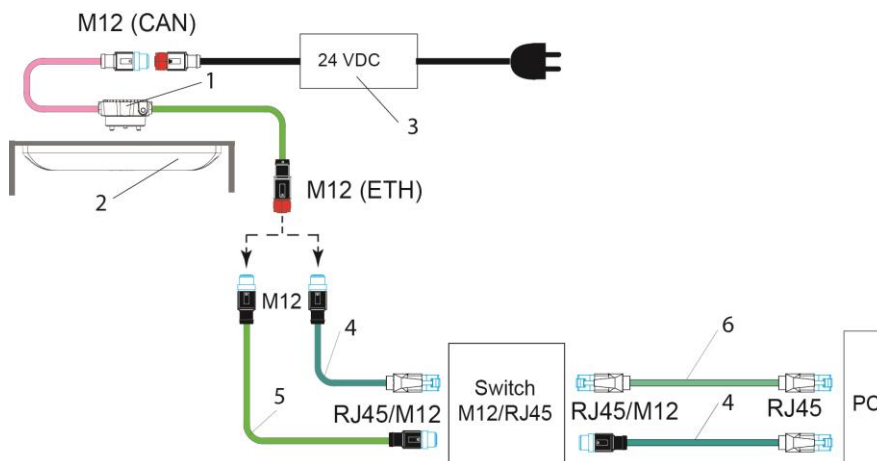

- 1 IRMA MATRIX sensor (flush mount or surface mount version)
- 2 Standard connector with interfaces CAN and Ethernet of type **sCON-S-CAN-ETH-23-Kq-x-y**
- 3 **Power block 24 V-M12**
- 4 Adapter cable for connection to the RJ45-switch **KQ-M12CAT5-RJ45-01-xm**
- 5 M12 Ethernet system cable for connection to the M12-switch **K-M12CAT5-XX-xm**
- 6 Commercial patch cable with 2x RJ45 connectors

M12 male connectors are marked by blue contours
M12 female connectors are filled in red



M12 connector (m, f) of type CAN are 5 pole and A coded.



M12 connector (m, f) of type ETH are 4 pole and D coded

Figure 4: PC connection with **sCON-S-CAN-ETH-23-Kq-x-y** standard

6.2 PC connection with a standard connector of the sCON-S-ETH-22-Kq-x-y type

This sCON is installed in vehicles fitted with a switch. On installation the sensor power supply is connected as specified in the installation instructions. Connect the PC to the switch using suitable cables, see Figure 5, item 5.



For service work, you first need to ascertain the connector type of the switch. An adapter can be necessary. The most common types are e.g.: SUB-D9, RJ45, M12 (D coded).

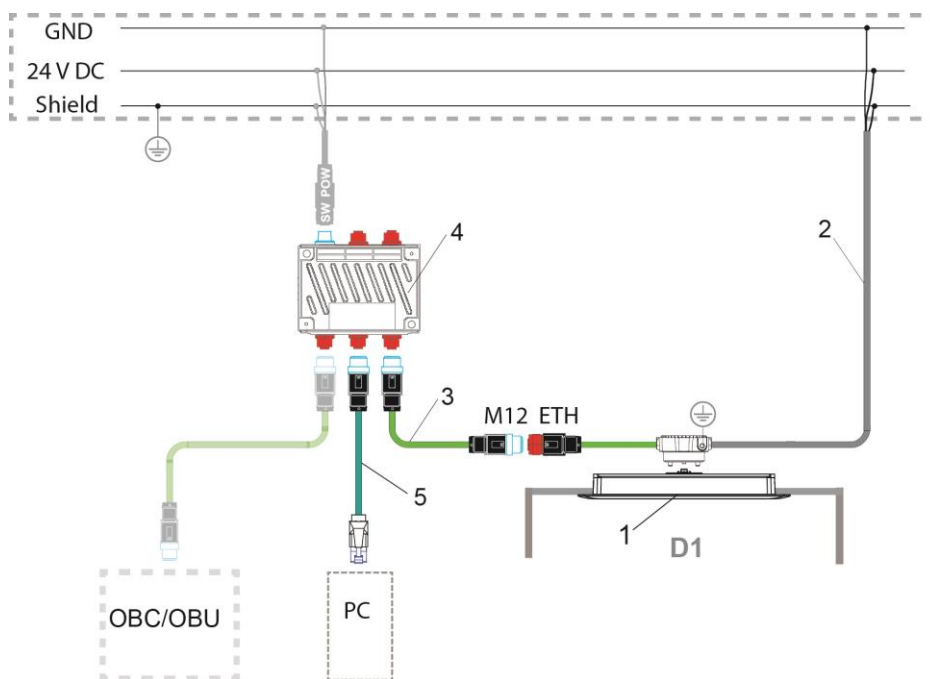

1 IRMA MATRIX sensor **DIST500-A/DIST500-F**
(surface mount or flush mount version)

2 Standard connector with Ethernet interface:
sCON-S-ETH-22-Kq-x-y

3 M12 system cable type ETH, **K-M12CAT5-XX-x**

4 Switch e.g. **Switch-M12-5Port-eCon**

5 M12-RJ45 adapter cable type ETH
KQ-M12CAT5-RJ45-01-xm

OBC/OBU:

On-Board Computer/On-Board Unit

D1 Door 1

M12 male connectors are marked by blue contours

M12 female connectors are filled in in red



M12 connector (m, f) of type ETH are 4 pole and D coded.

Figure 5: PC connection with sCON-S-ETH-22-Kq-x-y

7 Starting the service software

7.1 Before the first run of the service software program

In order to prevent communication problems, the communication path is determined for all service software variants. Before the first run of a service software tool please proceed as follows:

1. Mark the program icon on the desktop, right-click and select "Properties". The "Properties ..." windows opens.
2. Click into the input window "Target", see Figure 6.
3. Directly behind "DIST500-Configuration.exe" enter the following string:
[1 x space]-ipaddr=10.0.0.55
The characters "10.0.0.55" must correspond to the address which had before been entered as the IP address for the PC (see section [4.1](#) on page [7](#)).
4. Click "OK" to save the entry.

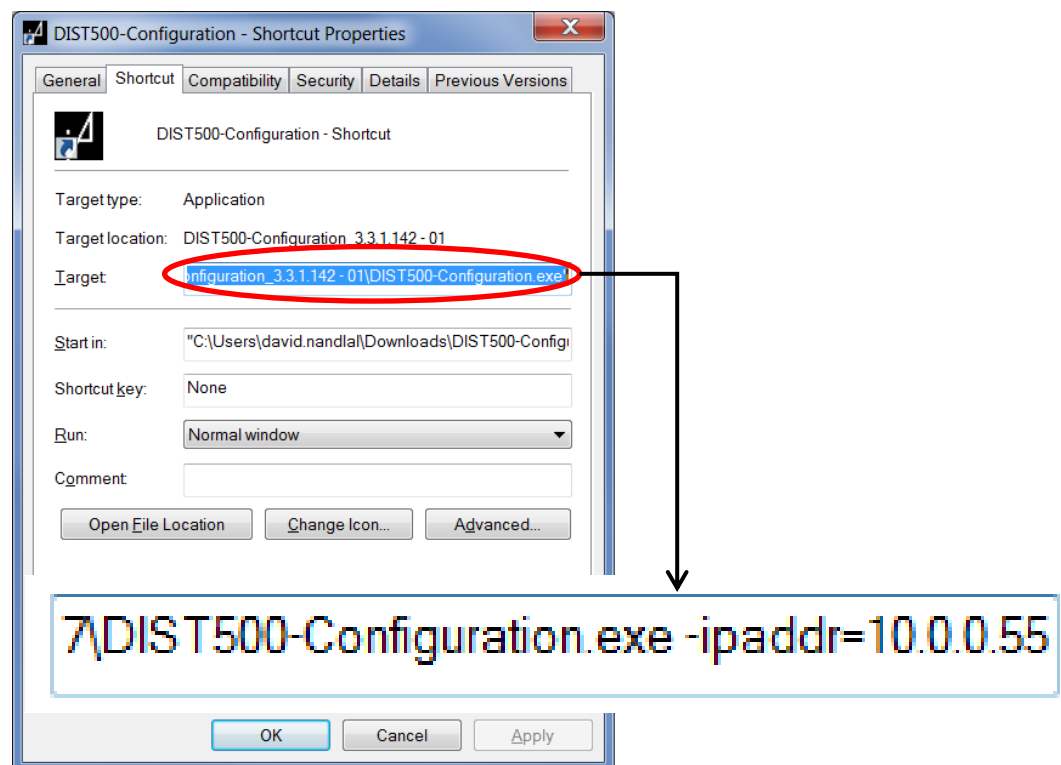

Figure 6: Entry in the "Properties" window of a service software tool

7.2 Important at each start of the software



Always switch the sensor on first via the switch on the PC. Then activate the power supply. In some cases a sensor RESET may be necessary. For this purpose disconnect the sensor from its power supply for a period of approx. 3 s. Then start the service software tool.

7.2.1 DIST500-Configuration_3.3.1.142 (or higher)

This software program is a tool enabling the entry of important configuration parameters via the PC. The most important parameter is the installation height. After sensor mounting it must be set to the actual installation height of the sensor.



Please refer to the "IRMA-MATRIX-Configuration-Tool" operating instructions for more detailed information.

7.2.2 DIST500-Visualization_4.2.0.112 (or higher)

This software program is a tool for the representation of the ongoing counting process and the monitoring range of a sensor. Simultaneously the height measurement of the sensor in a two-dimensional range is shown in real time. The representation of different heights by different colors yields an image appearing to be three-dimensional of the movement of any moving object underneath the sensor.



Please refer to the "IRMA-MATRIX-Visualization-Tool" operating instructions for more detailed information.

7.2.3 IRMA TestRide 2.8.1.37 (or higher)

This software program enables the determination of the counting accuracy at several doors simultaneously by comparing the sensors' counting results with the counting results obtained manually at the same time (e.g. on test rides).



Please refer to the "IRMA-TestRide" operating instructions for more detailed information.

8 Restoring the initial state at the PC



On conclusion of the work with the sensor on the PC the modified settings for the network adapter must be reset. This can be omitted only if the IP address of the sensors was made as a second IP entry.

In order to prevent unnecessary PC reboots, it has proven successful to restore the previous settings of the network adapter even before the PC-sensor connection is interrupted. For this purpose observe the instructions in section 4.1, page 7, up to item 3. Here the setting "Get IP address automatically" must be activated again.